

## An Analysis of Harmonic Mitigation to Reduce Transmission Losses in Power System

Apurva Ganguli\*, Abhay Kumar Sharma\*\*, V.K. Bajpai\*\*\*

Gyan Ganga Institute of Technology and Science.(G.G.I.T.S), Jabalpur, M.P., India

\*( Scholar, M. Tech. (Energy Technology) G.G.I.T.S, Jabalpur, M.P., India)

\*\* (Associate Professor Department of Mechanical, G.G.I.T.S, Jabalpur (M.P.), India)

\*\*\* (Professor Department of Electrical, G.G.I.T.S, Jabalpur (M.P.), India)

### ABSTRACT

The application of power electronics devices such as arc furnaces, adjustable speed drives, computer power supplies etc. are some typical non-linear characteristic loads used in most of the industrial applications are increasing rapidly due to improved technical devices, digital controller and flexibility in controlling the power usage. The use of the above power electronic devices in power distribution system gives rise to harmonics and reactive power disturbances. The harmonics and reactive power cause a number of undesirable effects like heating, equipment damage and electromagnetic interference effects in the power system. There are many conventional method to mitigate the harmonics but they are giving not satisfactory result To achieve a satisfactory harmonic content, the number of pulses being increased up to 48-pulses, in the present work the voltage source inverter (VSI) based on 48-pulses is used; this is constituted by four three-level converters linked by four phase-shifting transformers. This device exhibits a low harmonic rate on the AC side. The 48-pulses StatCom can be utilized in high power applications without AC filters. The StatCom is used in voltage regulation mode and it can be used as compensator (Var mode). Simulation results are plotted to show the appropriateness of the proposition. A comparative study on the performances of voltage and harmonic control strategies is being used in the present work and it has been observed from simulation result that these VSI have some disadvantages such as high cost, slow response, and large size etc., during real-time implementation But by using VSI one can avail the advantages like reconfigurable hardware designs, low cost developments, selection of bit width according to applications etc. A techno-economic analysis have also being carried, that shows approximately Rs.2 lack yearly saving with pay back of 6 years approx.

**Keywords** - Harmonic reduction in Power System, Power Factor Correction and Improve MVA Rating of transformer.

### I. BACKGROUND

In recent years both power engineers and consumers have been giving focus on the "electrical power quality" i.e. degradation of voltage and current due to harmonics, low power factor etc. Nearly two decades ago majority loads used by the consumers are passive and linear in nature, with a few non-linear loads thus having less impact on the power system. However, due to technical advancement in semiconductor devices and easy controllability of electrical power, non-linear loads such as SMPS, rectifier, chopper etc. are more used. The power handling capacity of modern power electronics devices such as power diode, silicon controlled rectifier(SCR), Insulated gate bipolar transistor (IGBT), Metal oxide semiconductor field effect transistor(MOSFET) are very large, so the application of such semiconductor devices is very popular in industry as well as in domestic purpose. While these advantages are certainly good but the excessive use of power electronic devices causing

great problem, i.e. generation of reactive power in the power system network. As a result, the voltage at different buses of power system network is getting distorted and the utilities connected to these buses are not operated as designed. The harmonic current and voltage pollute the power system causing problems such as transformer overheating, voltage quality degradation, rotary machine vibration, destruction of electric power components and malfunctioning of medical facilities, voltage flickering etc. To provide clean power at the consumer-end many types of power electronics devices are being used and are under study. GTO (Gate turn-off thyristors), FACT, 48Pulse Statcom etc. Implemented to the 48pulse voltage source convertor giving a number of advantage. A shunt connected 48 pulse convertor connected to the power system at the point of common coupling (PCC). Due to use of non-linear loads, the load current and voltage is highly nonlinear in nature. The compensating current and voltage which is output of the VSC is injected at PCC, so the

harmonic cancellation takes place and the current and voltage between sources to PCC is sinusoidal in nature.

## II. Harmonic extraction:

Harmonic extraction is the process in which reference current is generated by using the distorted waveform. Many theories have been developed such as p-q theory (instantaneous reactive power theory), d-q theory, frieze controller, PLL with fuzzy logic controller [23], neural network etc.. Out of these theories, more than 60% research works consider using p-q theory and d-q theory due to their accuracy, robustness and easy calculation. The method are as follows:-

### p-q Method

Instantaneous reactive power theory has been published in 1984. Based on this theory, the so-called "p-q method" was applied successfully in the control of AHF. Zero-sequence component is neglected in this method, and because of that the p - q method is not accurate when the three-phase system is distorted or unbalanced.

### d-q Method

Based on the park transformation, the d - q method came. The three-phase load current can be decomposed in positive-sequence, negative sequence and zero-sequence component. The current in the d - q frame  $i_d$  and  $i_q$  can be transformed from the positive sequence and negative sequence using a PLL (phase locked loop). The division of the AC and DC components can be obtained across allow-pass PHF. The reference current signal can be achieved by the AC component in d - q frame through a counter transformation.

## III. Literature Survey

1996 D.A.Paice in his work had predicted the different multi-pulse AC to DC converters for solving the harmonic problem in a three-phase converter system. Their effects by increasing the number of pulses on the performance of AC to DC converters has been analyzed. For performance comparison the major factors considered are the ripple percentage, form factor and the total harmonic distortion (THD). The effects of load variation on multi-pulse AC to DC converters have also been investigated.[1]

1996 K.Dubey, S.R.Doradla, A.Joshi, and R.M.K.Sinha suggested that the use of multiple converters or multiple semiconductor devices with a common load. depict the various techniques for the reduction of harmonics.[19] 1997 M. S. El-Moursi , A. M. Sharaf, J. C. J. Hatziaodoniu and F.

E.Chalkiadakis put emphasis on two 24-pulse GTO converters, phase-shifted by 7.5o from each other, are used to provide the full 48-pulse converter operation. The 48-pulse converter comprises of four identical 12-pulse GTO converters interlinked by four 12-pulse transformers with phase-shift windings [2, 3].

1998 CIGRE predicted that commercial availability of Gate turn-off thyristor (GTO) devices with high power handling capability, and the advancement of other types of power semiconductor devices such as IGBT's, have led to the development of controllable reactive power sources utilizing electronic switching converter technology [4].

2002 N.Mohan, T.M.Undeland and W.P.Robbins in their paper shown the performance improvement of multi-pulse converter is achieved for total harmonics distortion (THD) in supply current, DC voltage ripples and form factor. All the simulations have been done for similar ratings of RL Load, for all the multi-pulse converters configurations, so as to represent a fair comparison among controlled and uncontrolled continuations of multi-pulse converters. The presented simulation results show the reduced THD at supply side. These results agree with the IEEE Standards 519-1992. Effect of increase in number of pulses in converter circuits for uncontrolled and controlled multi pulse converter on input supply current and DC side voltage and current has been presented in this work [5].

2003 M.S. El-Moursi. A.M. Sharaf and Eskandar Gholipour Shahraki in their work said that the StatCom regulates the voltage magnitude at its terminals by controlling the amount of reactive power injected into or absorbed from the power system. When system voltage is low, the StatCom generates reactive power (StatCom capacitive); when system voltage is high, it absorbs reactive power (StatCom inductive)[6] [7].

2008 Singh, S.Gairola, B.N.Singh, A.Chandra, and K.A.Haddad in his experiment had used multi-pulse methods involve multiple converters connected so that the harmonics generated by one converter are cancelled by harmonics produced by other converters. By this means, certain harmonics related to number of converters are eliminated from the power source. In multi-pulse converters, reduction of AC input line current harmonics is important as regards to the impact the converter has on the power system.[8]

## INTRODUCTION

Harmonics" means a component with a frequency that is an integer multiple (where n is the order of harmonic) of the fundamental frequency; the first harmonic is the fundamental frequency (50 or 60 Hz). The second harmonic is the component with

frequency two times the fundamental (100 Or 120 Hz) and so on. As shown in Fig.2.1 harmonic distortion can be considered as a sort of pollution of the electric system which causes problems if the sum of the harmonic currents exceeds certain limits. The utilization of electrical power mainly depends upon supply of power with controllable frequencies and voltages, where as its generation and transmission

takes place at nominally constant levels. So to convert nominal frequency to variable frequency power electronics circuitry (non-linear loads) is needed, which distorts the voltage and current waveforms. Therefore, the main source of harmonics in the power systems is the non linear loads

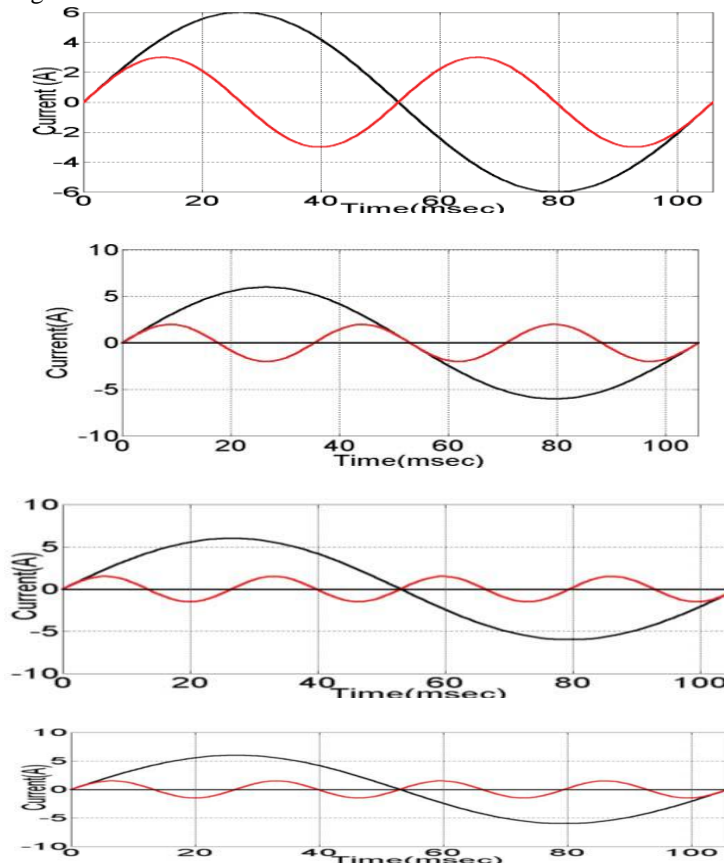

Figure . 2.1 A sinusoidal waveform with fundamental frequency 50 Hz and its harmonics: (a) second(100 Hz); (b) third (150 Hz); (c) fourth (200 Hz); (d) fifth (250 Hz)

The French mathematician Jean Baptiste Joseph Fourier (1768–1830), demonstrated that any periodic waveform can be deconstructed into a sinusoid at the fundamental frequency with a number of sinusoids at harmonic frequencies. A DC component may complete these purely sinusoidal terms. This concept can be explained by the following equation:

$$\begin{aligned}
 f(x) &= \frac{a_0}{2} + \cos x + b_1 \sin x + a_2 \cos 2x + b_2 \sin 2x + \dots \\
 &\dots + a_n \cos nx + b_n \sin nx \\
 &= \frac{a_0}{2} + \sum_{n=1}^{\infty} (a_n \cos nx + b_n \sin nx) \\
 &= \frac{a_0}{2} + \sum_{n=1}^{\infty} C_n \sin (nx + \phi_n)
 \end{aligned}$$

Where  
 $f(x)$  = General Periodic Waveform  
 $a_0$  = D.C. Component  
 $a_n, b_n$  = coefficient of the series  
 $n$  = integer  
 $T = 2\pi$  Time period

$$\begin{aligned}
 a_0 &= \frac{1}{\pi} \int_0^{2\pi} f(x) dx, \\
 n &= \int_0^{2\pi} f(x) \cos(nx) dx, \\
 x &= \sqrt{a_n^2 + b_n^2} \phi_n = \tan^{-1} \frac{b_n}{a_n}
 \end{aligned}$$

#### IV. METHODS OF HARMONIC MITIGATION

Many methods are being used to reduce harmonics in the power system and increase the power quality of the system like active power filters ,passive filters ,shunt compensators, series compensators etc are some methods which are being used to mitigate harmonics in the power system. In the present paper 48 pulse Statcom is being used to reduce harmonics in the power system

#### V. SIMULATION MODEL

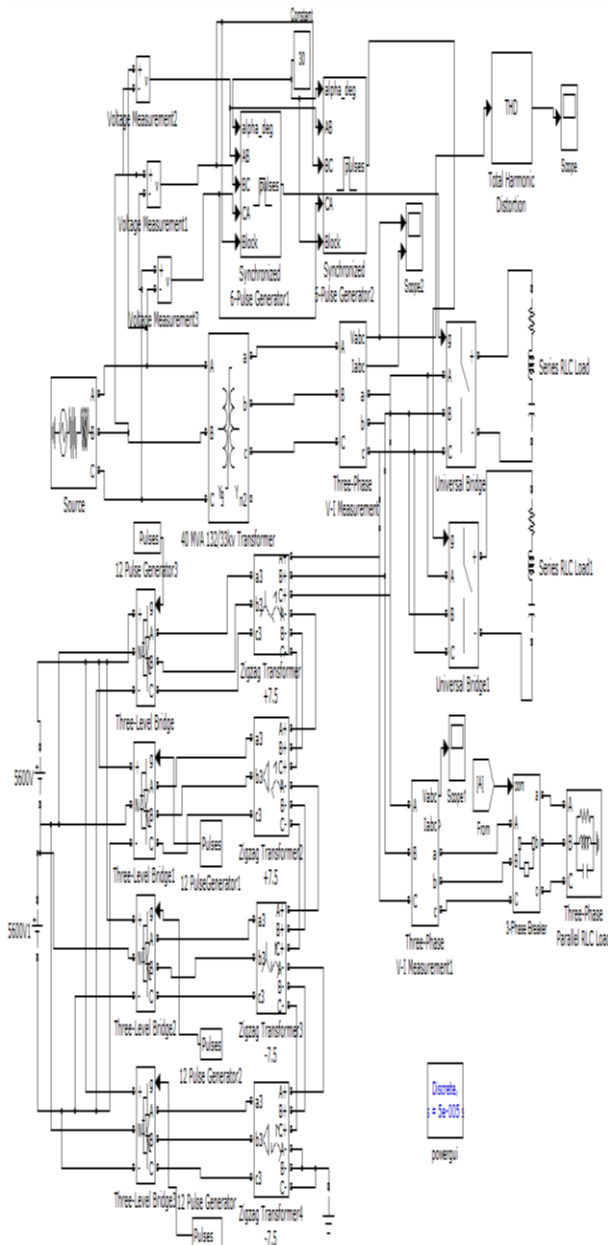

Symatic arrangement of 48-pulse voltage convertor with the 33KV power system

#### VI. SYSTEM PARAMETERS

Sr.No.	Equipments list	Parameter description
1	Three –phase source	Voltage ph-ph =130KV
2	System transformer step down	40MVA,132/33KV
3	Three phase constant voltage at 33KV side	
	Voltage	31.36Kv
	Frequency	50Hz
4	Statcom	
	Frequency	50Hz
	Capacitance	3000 μF
5	4 numbers phase shift zig-zag transformer	1 MVA (each)
6	GTO switch	
	Snubber resistance	1e-5 (ohm)
	Snubber capacitance	1Inf
	Internal resistance	1e-4 (ohm)
	No. of bridge arm	3
7	4 number of pulse generator	12 pulse (each)

## VII. SIMULATION RESULT

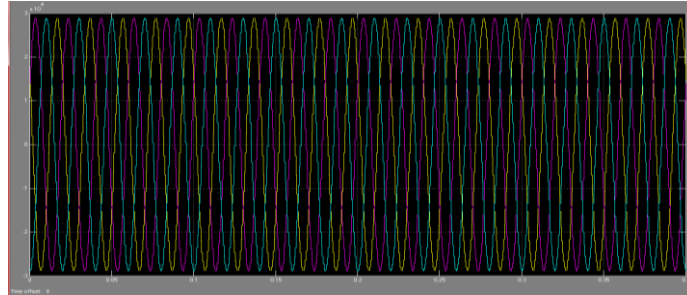

Voltage  $V_{abc}$  without Harmonic Correction(Y axis – Voltage in V, X axis - time in millisecond)

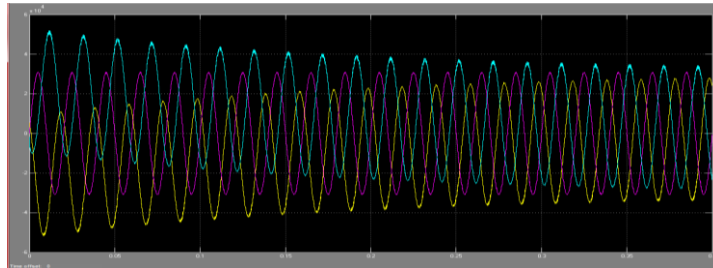

Voltage  $V_{abc}$  after harmonic correction(Y axis – Voltage in V, X axis - time in millisecond)

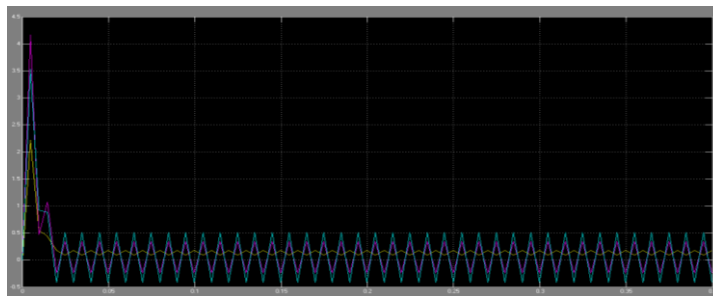

THD graph of voltage  $V_{abc}$  without harmonic correction(Y axis – THD, X axis - time in millisecond)

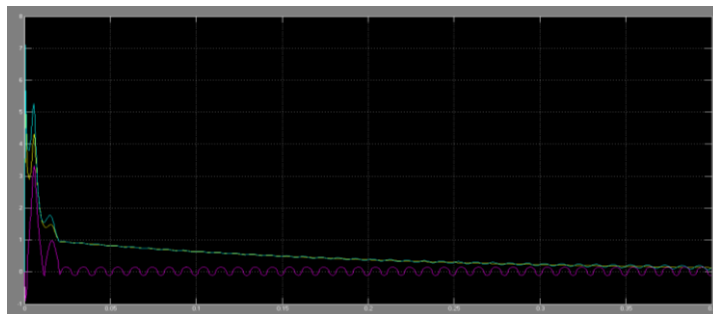

THD graph of voltage  $V_{abc}$  after harmonic correction(Y axis – THD, X axis – time in millisecond)

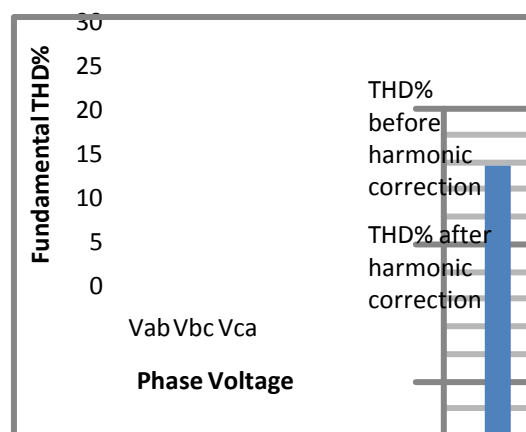

THD% Graph for phase Voltage

### VIII. CONCLUSION

The StatCom is shunt devices used to help in improve the voltage contents in the transmission system. Its main function is generating or absorbing reactive power through a voltage source converter. Six pulse convertor is the simplest model of this configuration. However, multi-pulses configurations are able to generate voltage waveforms with a reduced harmonic content; thus, filters are not required. The StatCom's dynamic response is fast and able to pass from a capacitive mode of operation to an inductive one, in a few cycles. When the AC voltage decreases, the StatCom reacts by generating reactive power, so the DC voltage increases; this is the capacitive mode. On the other hand, when the AC voltage increases, the StatCom reacts by absorbing reactive power, so the DC voltage decreased; this is the inductive mode [9]. When the StatCom is used as compensator, the move from capacitive to inductive mode, is very fast [10]. These also help to reduce MVA loading on transformer up to 6.7% by improving power factor quality of the power system.

### REFERANCE

[1] [2] D.A.Paice, Power Electronic Converter Harmonics-Multi-pulse Methods for Clean Power. New York,IEEE Press, 1996.  
 [2] J. C. J. Hatziadoniu and F. E.Chalkiadakis, "A 12-Pulse StaticSynchronous Compensator for the distribution system employing the3-level GTO-Inverter", *IEEE Trans. On Power Delivery*, vol.12,no.4,October 1997,pp .1830-1835.  
 [3] M. S. El-Moursi and A. M. Sharaf, "Novel Controllers for the 48 Pulse VSC STATCOM and SSSC for Voltage Regulation and Reactive Power Compensation," *IEEE Trans. On Power System*, vol. 20, no.4,nov. 2005, pp. 1985 – 1997.

[4] CIGRE, "Static Synchronous Compensator", working group 14-19,September1998  
 [5] N.Mohan, T.M.Undeland, W.P.Robbins, —PowerElectronics: Converters, Applications, and Design||, 3rd Edition, 2002  
 [6] M.S. El-Moursi. A.M. Sharaf « Novel reactive power controllers for the StatCom and SSSC », *Electric Power*  
 [7] Eskandar Gholipour Shahraki « Apport de l'UPFC à l'amélioration dla stabilité transitoire des réseaux électriques » thesis, Henri Poincaré, Nancy-I university, October 2003  
 [8] B.Singh, S. Gairola, B.N.Singh, A.Chandra, and K.A. Haddad, —Multi-pulse AC-DC Converter for Improving Power Quality: A Review|| *IEEE Transactions, On Power Delivery*, Vol.23 No.1January 2008.  
 [9] F. Ghezal ; S. Hadjeri ; S.A. Zidi ; F. Gherbi H.BoudjellaB.Razkallah, « Behaviour of a three-level 48-pulses StatCom », attheconference « the second international conference . on electrical andelectronics engineering : ICEEE' 08, 21-23 avril, Laghouat, Algeria.  
 [10] Lazlo Narain G. Hingorani, Laszlo Gyugyi, « understanding FACTS concepts and technologie», book, john wiley and son, IEEEorder N° Pc 5713, 2000.